

Dedilhados para a flauta doce, de Blocki

fá 1ª oitava			fá 1ª oitava
fá#/solb 1ª oitava			fá#/solb 1ª oitava
sol 1ª oitava			sol 1ª oitava
sol#/láb 1ª oitava			sol#/láb 1ª oitava
lá 1ª oitava			lá 1ª oitava
lá#/sib 1ª oitava			lá#/sib 1ª oitava
si 1ª oitava			si 1ª oitava

-- Dedilhado renascentista -- Contralto

-- Dedilhado renascentista -- Contralto



<p>dó 1ª oitava</p>			<p>dó 1ª oitava</p>
<p>dó#/réb 1ª oitava</p>			<p>dó#/réb 1ª oitava</p>
<p>ré 1ª oitava</p>			<p>ré 1ª oitava</p>
<p>ré#/mib 1ª oitava</p>			<p>ré#/mib 1ª oitava</p>

-- Dedilhado renascentista -- Contralto

				<p>mi 1ª oitava</p>
		<p>mi 1ª oitava</p>		<p>fá 2ª oitava</p>
		<p>fá 2ª oitava</p>		<p>fá#/solb 2ª oitava</p>





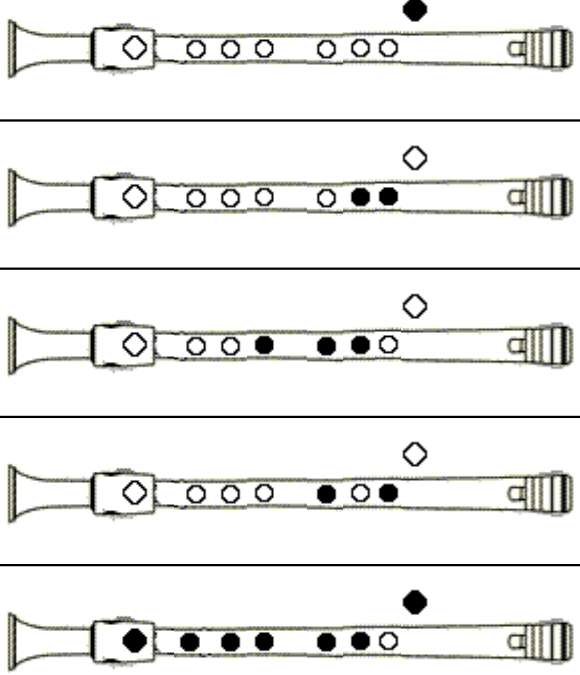
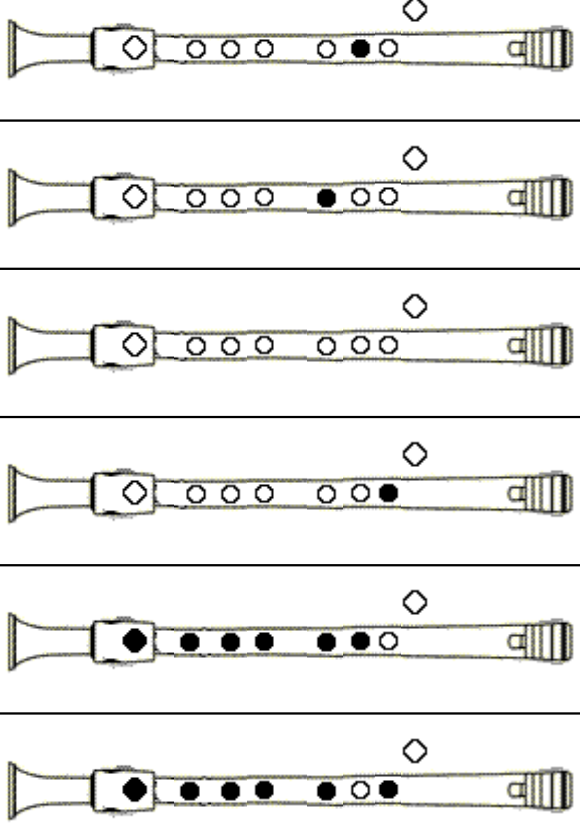
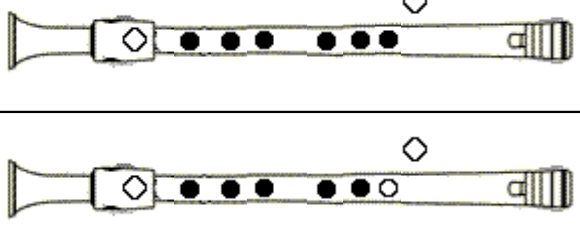



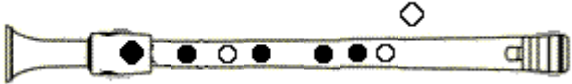

-- Dedilhado renascentista -- Contralto

4 (9)



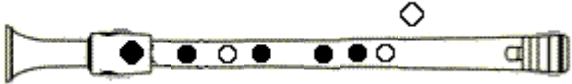



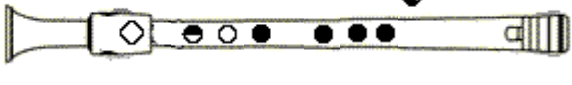
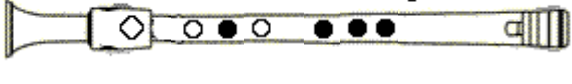







	<p>sol 2ª oitava</p> 	<p>sol#/láb 2ª oitava</p> 
		

-- Dedilhado renascentista -- Contralto

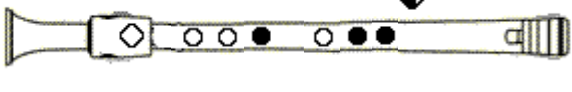

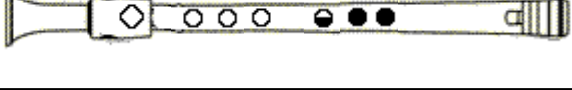

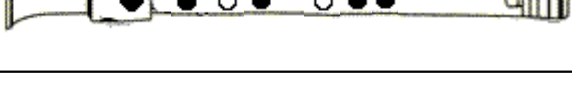
5 (9)

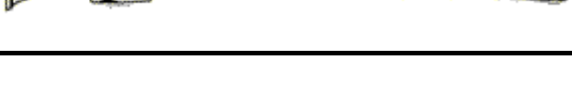
	<p>lá 2ª oitava</p> 	<p>lá#/sib 2ª oitava</p> 	<p>si 2ª oitava</p> 
			
			
<p>lá 2ª oitava</p>		<p>lá#/sib 2ª oitava</p> 	<p>si 2ª oitava</p> 



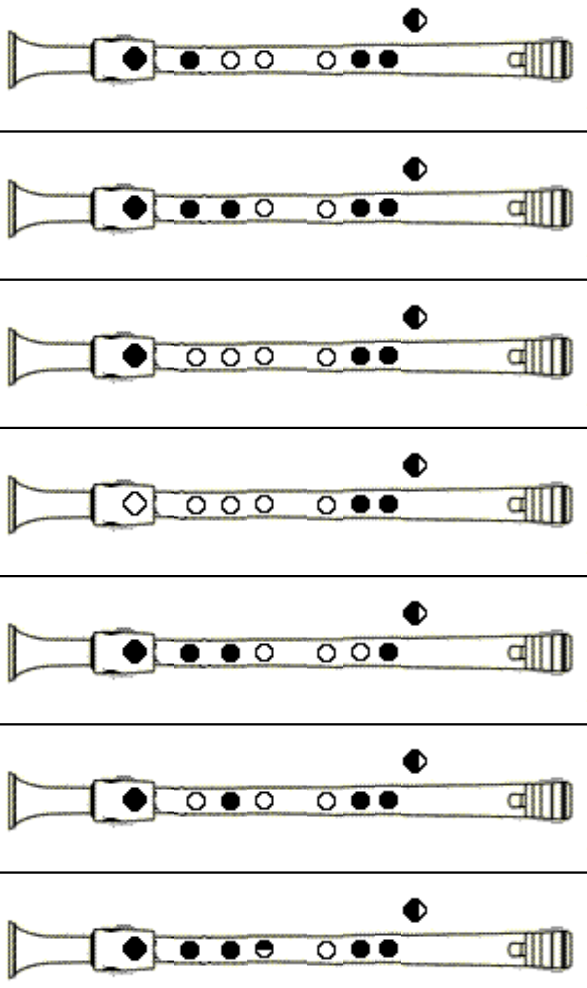

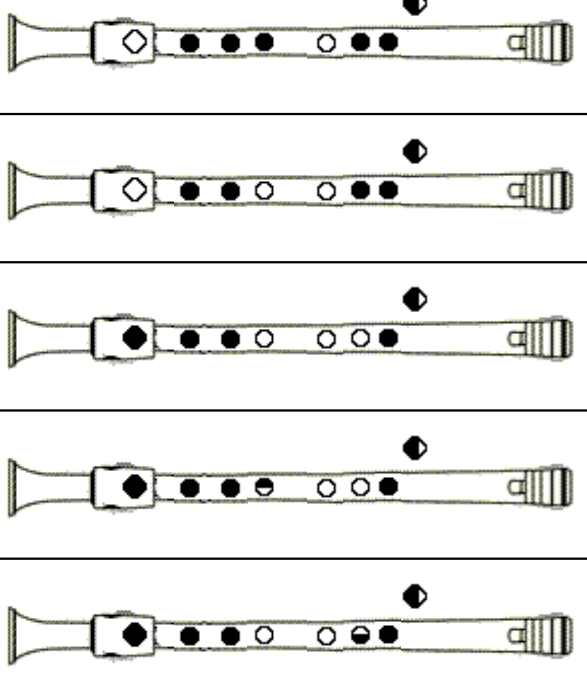
-- Dedilhado renascentista -- Contralto

	<p>dó 2ª Oitava</p> 	<p>dó#/réb 2ª Oitava</p> 
    		      
	<p>dó 2ª Oitava</p>	<p>dó#/réb 2ª Oitava</p>

-- Dedilhado renascentista -- Contralto

<p>ré 2ª oitava</p> 	
<p>ré#/mib 2ª oitava</p> 	 <p>apenas para legato</p>
<p>mi 2ª oitava</p>	 

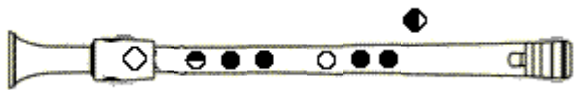
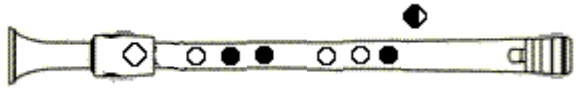
-- Dedilhado renascentista -- Contralto

	<p>fá 3ª oitava</p> 	<p>fá# / solb 3ª oitava</p> 	<p>sol 3ª oitava</p> 
			

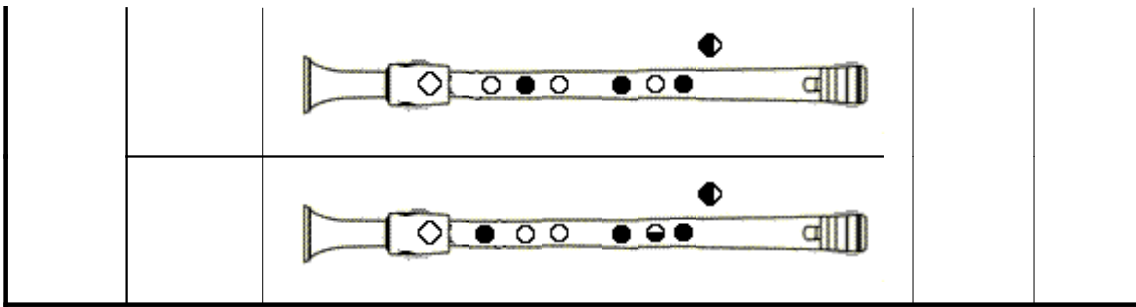

>>> O primeiro dedilhado é o recomendado, os outros são alternativos.

(FPDF/Arial)br-2019-07-16 [74.34/t161/]