

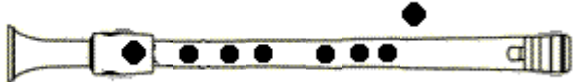













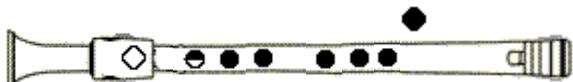

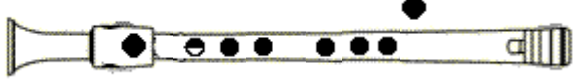



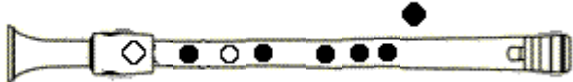

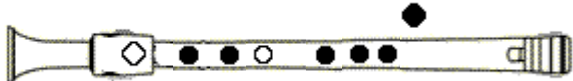

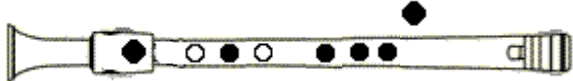
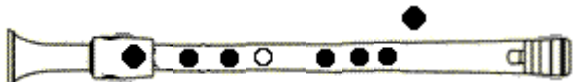
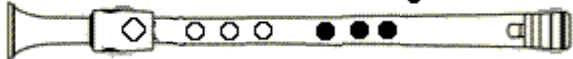
Dedilhados para a flauta doce, de Blocki

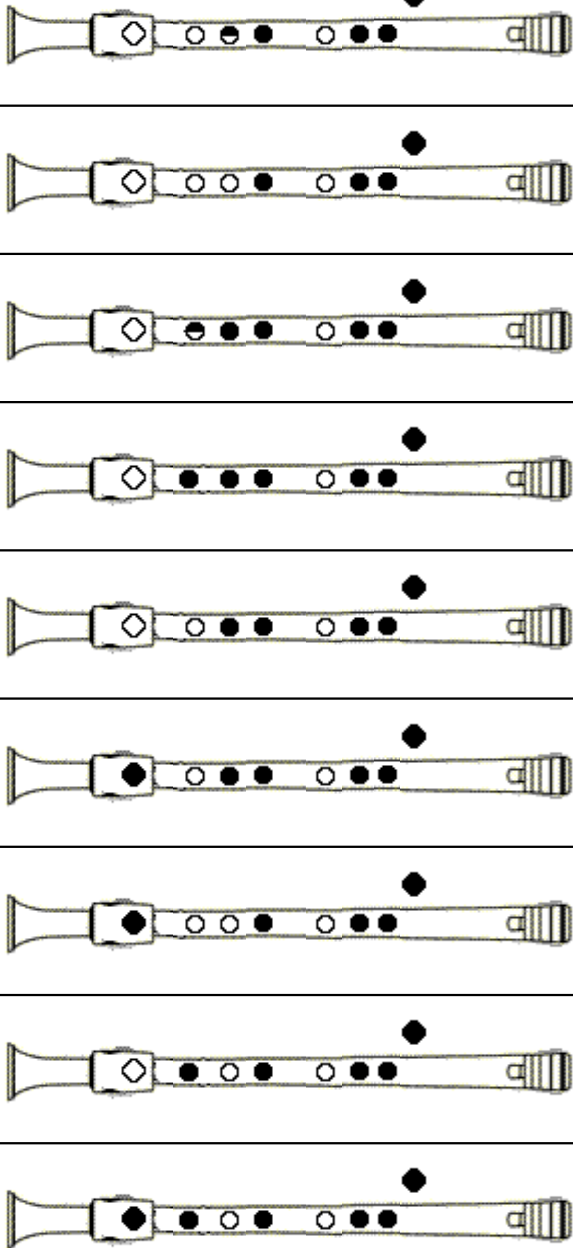
| | | | | |
|------------------------------|--|---|---|------------------------------|
| fá 1ª oitava | |  |  | fá 1ª oitava |
| fá#/solb 1ª oitava | |  |  | fá#/solb 1ª oitava |
| sol 1ª oitava | |  |  | sol 1ª oitava |
| sol#/láb 1ª oitava | |  |  | sol#/láb 1ª oitava |
| | |  | | |
| | |  | | |
| lá 1ª oitava | |  |  | lá 1ª oitava |
| lá#/sib 1ª oitava | |  |  | lá#/sib 1ª oitava |
| | |  | | |
| | |  | | |
| si 1ª oitava | |  |  | si 1ª oitava |
| | |  | | |
| | |  | | |

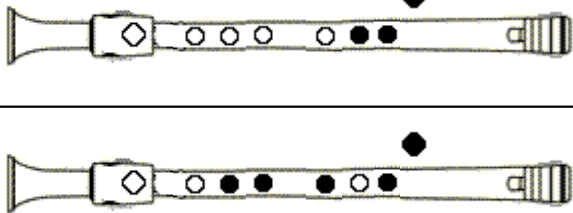

-- Dedilhado renascentista -- Baixo

-- Dedilhado renascentista -- Baixo

| | | | |
|-------------------------------------|---|---|-------------------------------------|
| <p>dó 1ª oitava</p> |  |  | <p>dó 1ª oitava</p> |
| <p>dó#/réb 1ª oitava</p> |  |  | <p>dó#/réb 1ª oitava</p> |
| <p>ré 1ª oitava</p> |  |  | <p>ré 1ª oitava</p> |
| <p>ré#/mib 1ª oitava</p> |  |  | <p>ré#/mib 1ª oitava</p> |

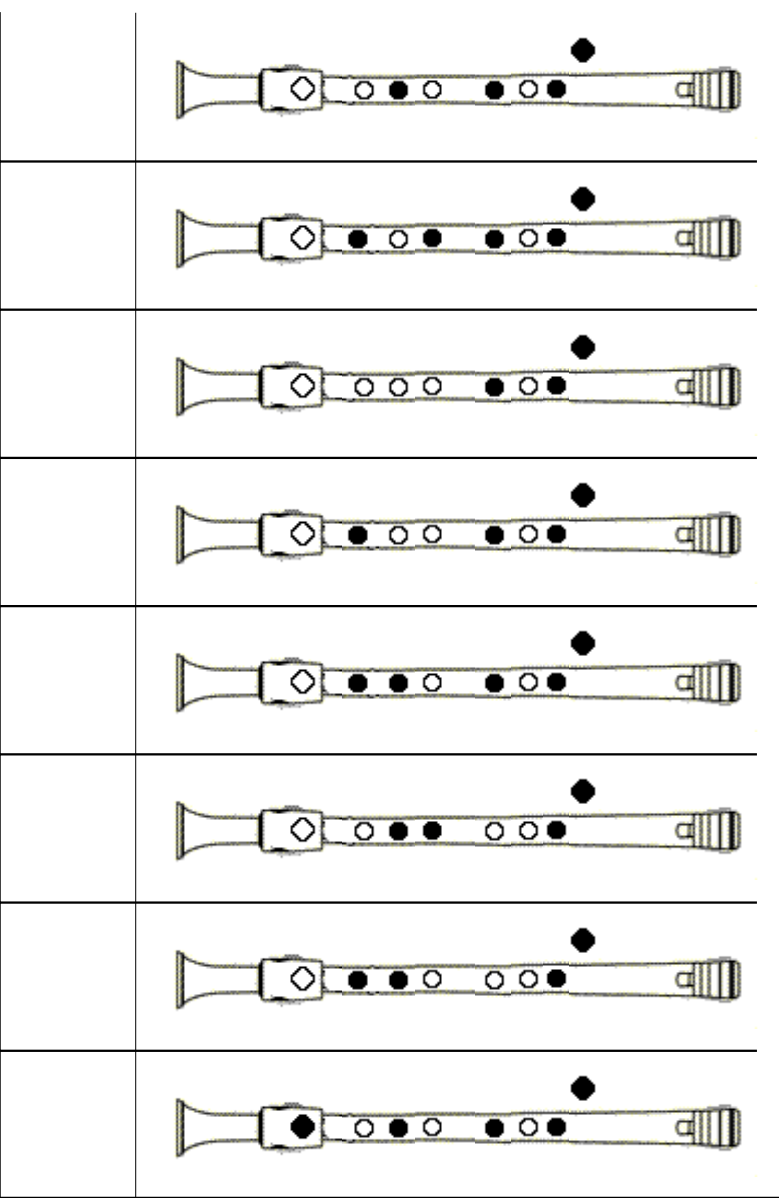
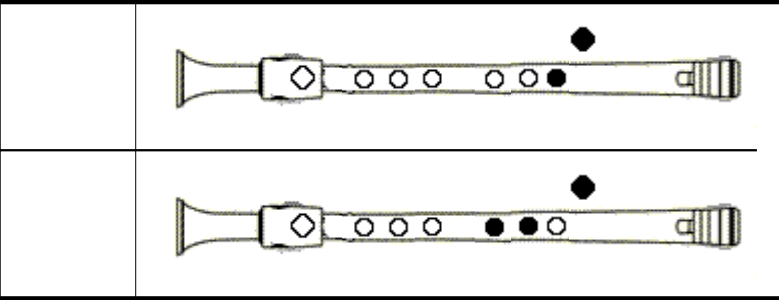
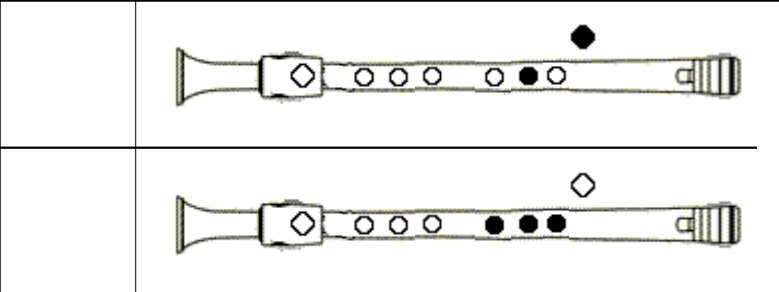
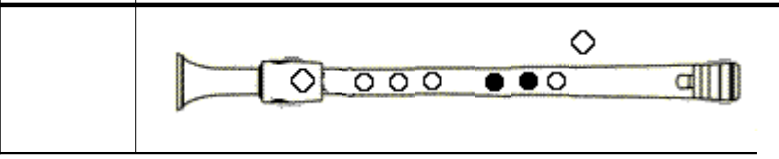

-- Dedilhado renascentista -- Baixo

3 (9)

| | | | |
|--|--|--|--|
| | <p>mi 1ª oitava</p>  | <p>fá 2ª oitava</p>  | <p>fá#/solb 2ª oitava</p>  |
|  |  |  |  |



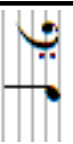

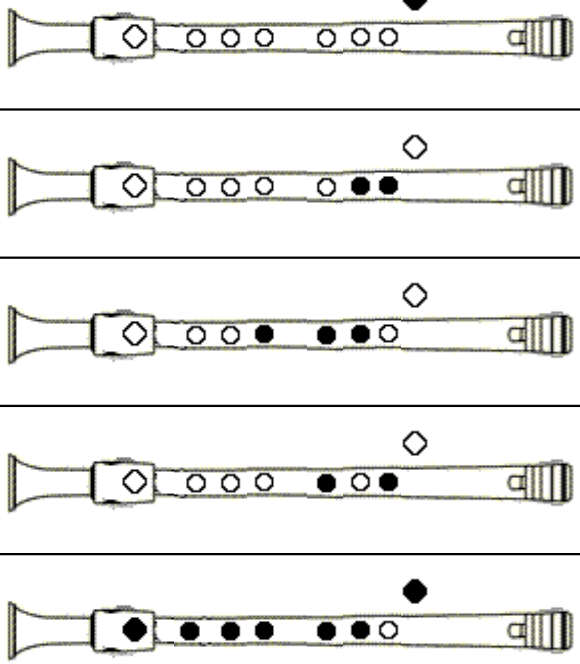
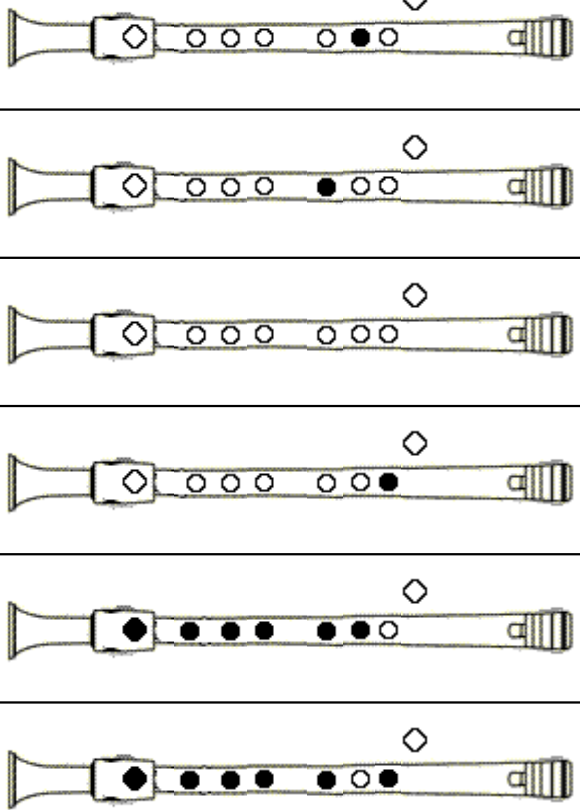
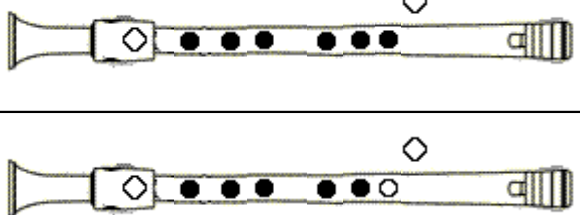

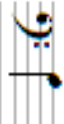
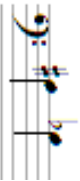
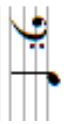

-- Dedilhado renascentista -- Baixo

4 (9)



| | | |
|---|--|--|
| | <p>sol 2ª oitava</p>  | <p>sol#/láb 2ª oitava</p>  |
|  |  |  |
| | <p>sol 2ª oitava</p> | <p>sol#/láb 2ª oitava</p> |

-- Dedilhado renascentista -- Baixo

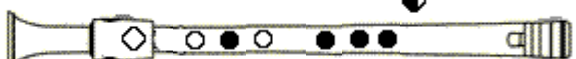

5 (9)

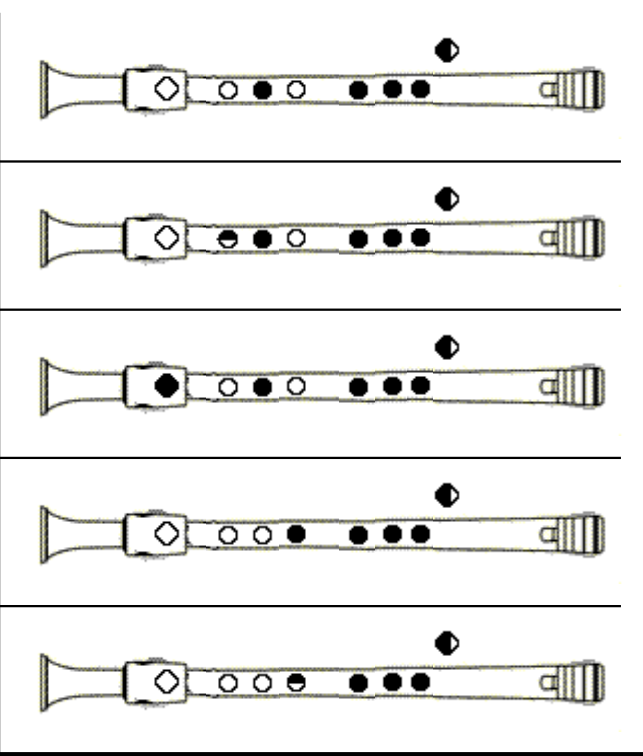
| | | | | |
|---|---|---|--|---|
| | <p>lá 2ª oitava</p>  | <p>lá#/sib 2ª oitava</p>  | <p>si 2ª oitava</p>  | |
|  |  |  |  |  |
| <p>lá 2ª oitava</p> |  | <p>lá#/sib 2ª oitava</p>  | <p>si 2ª oitava</p>  | |

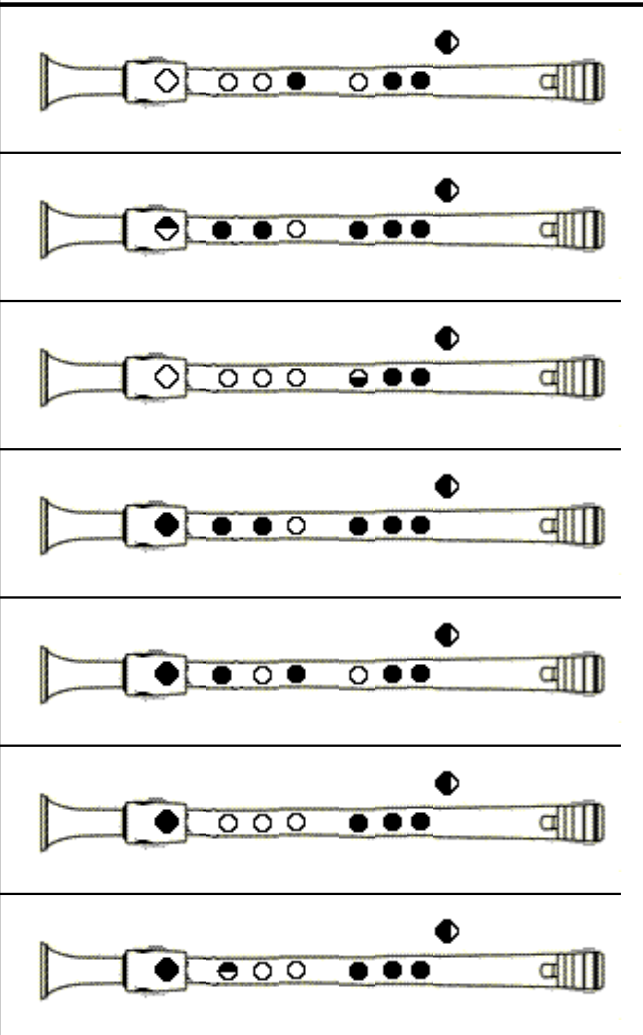
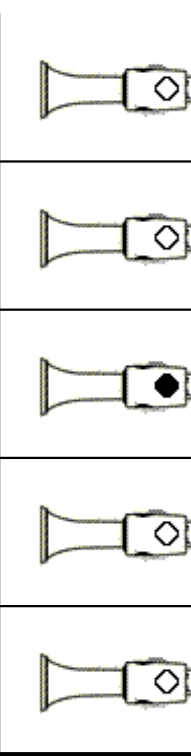
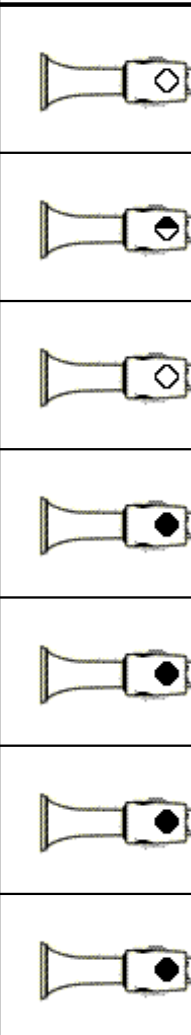

-- Dedilhado renascentista -- Baixo

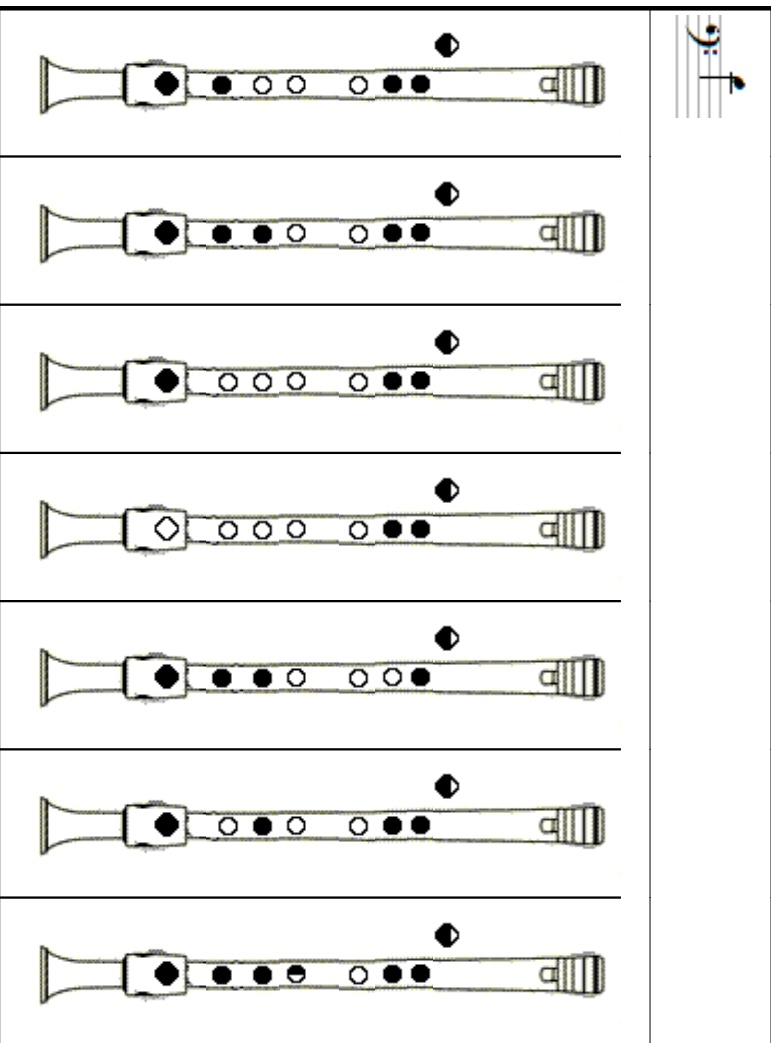
| | | |
|---|---|---|
| | <p>dó 2ª oitava</p>  |  |
| <p>dó#/réb 2ª oitava</p>  |  | |
| <p>dó 2ª oitava</p> | |  |
| <p>dó#/réb 2ª oitava</p> | |  |

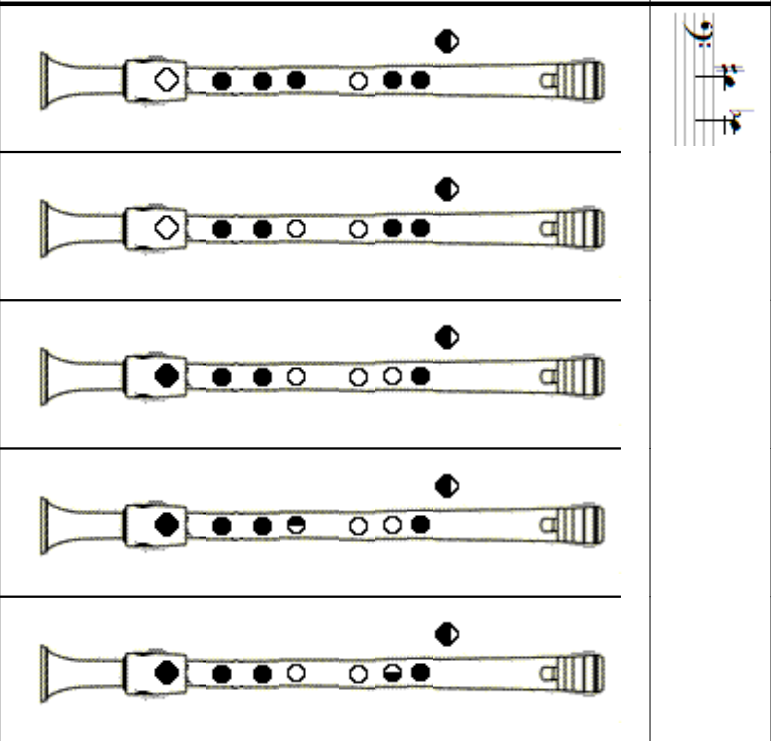
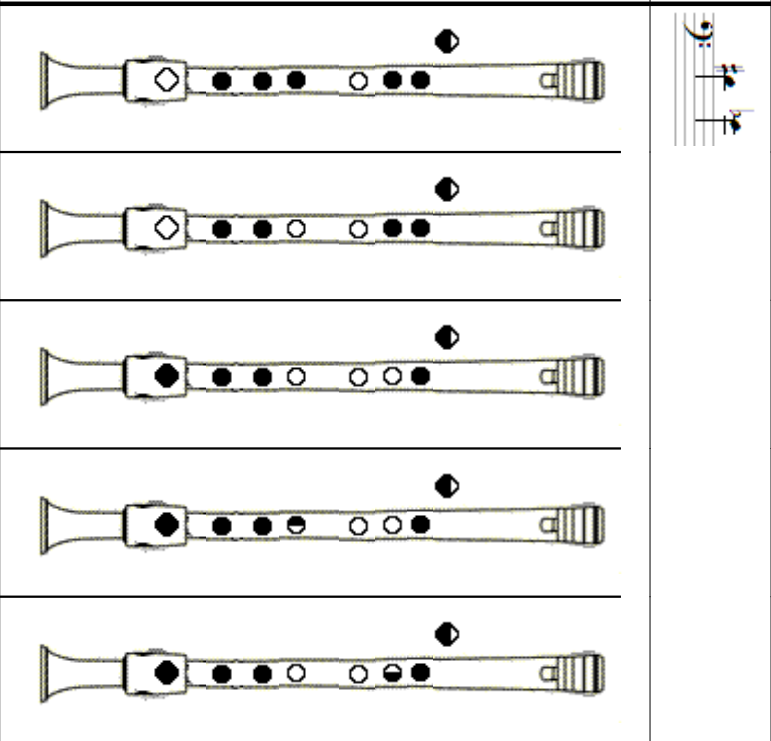
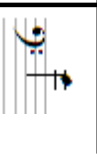
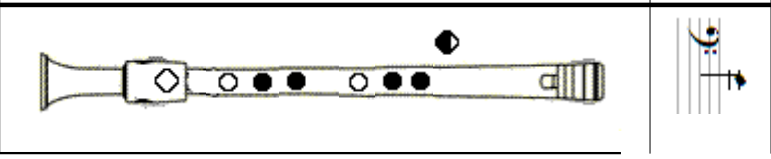
-- Dedilhado renascentista -- Baixo

| | |
|---|--|
| <p>ré 2ª oitava</p>  |  |
| <p>ré#/mib 2ª oitava</p>  |  |
| <p>ré#/mib 2ª oitava</p> <p>apenas para legato</p> |  |
| <p>mi 2ª oitava</p>  |  |

-- Dedilhado renascentista -- Baixo

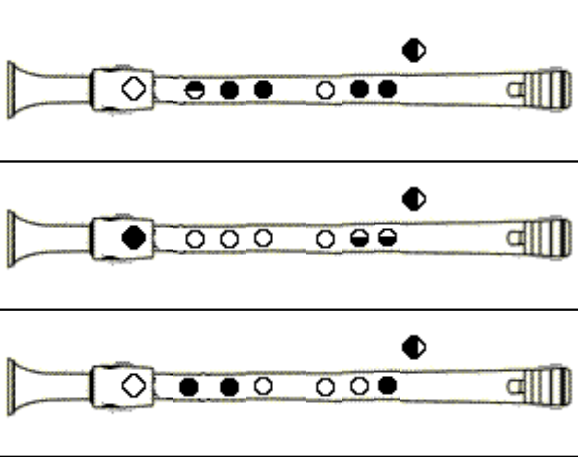
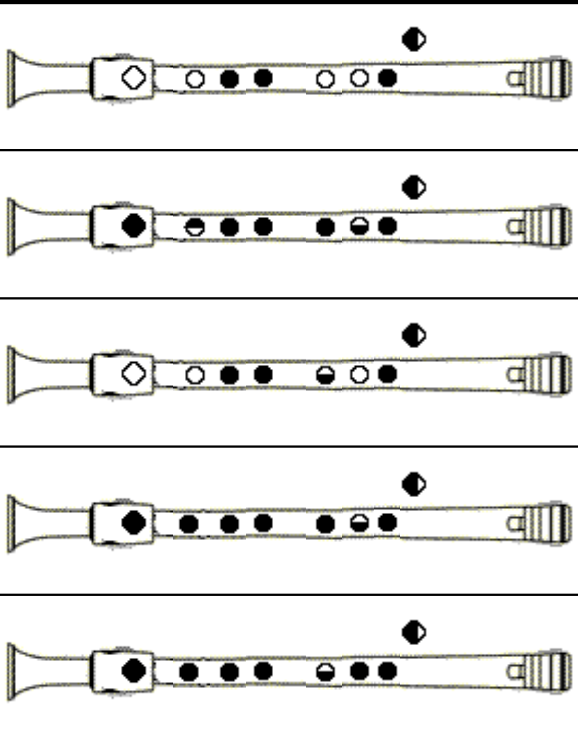
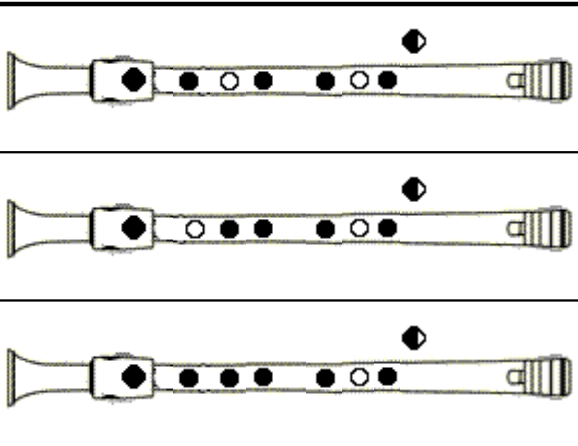
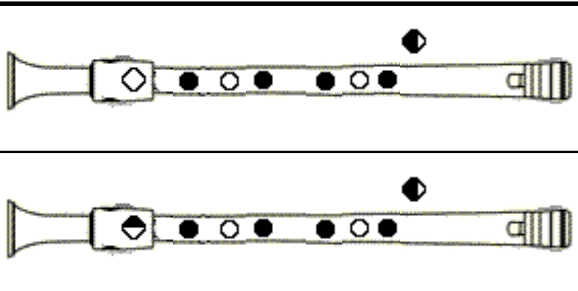
| | | | |
|---|--|--|---|
| | <p>fá 3ª oitava</p>  | <p>fá#/solb 3ª oitava</p>  | <p>sol 3ª oitava</p>  |
|  |  |  |  |

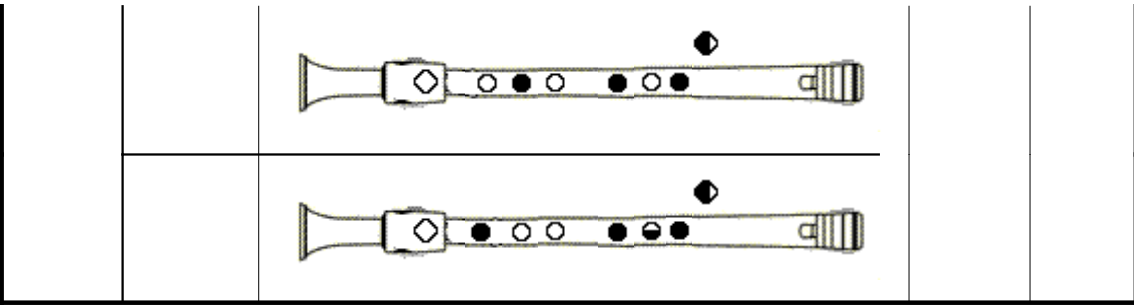

>>> O primeiro dedilhado é o recomendado, os outros são alternativos.

(FPDF/Arial)br-2019-07-16 [74.34/t161/]